

XA CONNECTOR

2.5 mm pitch/Wire-to-Board connectors/Crimp style and Mating style

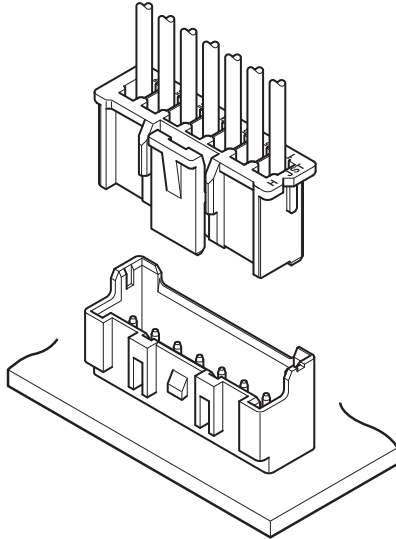

- Secure lock mechanism
- Solder crack prevention
- Low insertion force
- Insertion guide structure
- Applicable to automatic board mounting machine (Taping header)
- Polarizing boss

Specifications

- Current rating: 3 A AC/DC (AWG #22, AWG #20)
 - Voltage rating: 250 V AC/DC
 - Temperature range: -25°C to +85°C
(including temperature rise in applying electrical current)
 - Contact resistance:
 - Initial value/ 10 mΩ max.
 - After environmental tests/ 20 mΩ max.
 - Insulation resistance: 1,000 MΩ min.
 - Withstanding voltage:
 - There shall be no breakdown or flashover while applying 1,000 VAC for one minute.
 - Applicable wire range:
 - Conductor size/ AWG #28 to AWG #20
 - Insulation O.D. / φ 0.8 mm to φ 1.9 mm
 - Applicable PC board thickness: 1.6 mm
- * Please refer to the "Handling Precautions for Terminals and Connectors" on our website (listed in the "Technical Documents" column on the Product Information page) before use.
- * RoHS2 compliance
- * Dimensional unit: mm
- * Contact JST for details.

Standards

For information on overseas standard registrations, please refer to the "List of Registered Overseas Standards" on our website (listed in the "Technical Documents" column on the Product Information page).

* Specifications registered to overseas standards may differ from the general specifications listed above.

PC board layout and Assembly layout/ Through-hole type

Top entry type

- Without boss

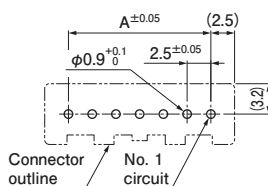

- With boss

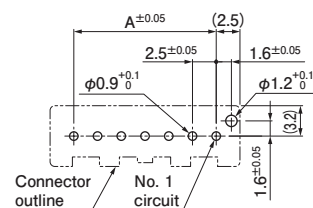

Housing: Standard type

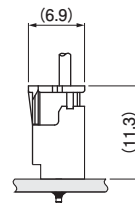

- Note: 1. The PC board layout figure shown is viewed from the connector mounting surface.
2. Dimensions A and D: See "Header" section on page 4.
3. Tolerance for the PCB hole pitch shall be ± 0.05, and shall not accumulate more than ± 0.05.
4. Hole dimensions differ depending on the type of PCB and PCB drilling method.
- The above dimensions are reference values. Please contact JST for details.

PC board layout and Assembly layout/ Through-hole type

Side entry type

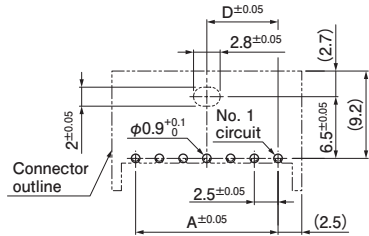

Housing: Standard type

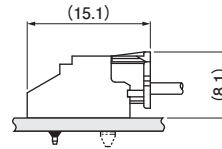

- Note: 1. The PC board layout figure shown is viewed from the connector mounting surface.
 2. Dimensions A and D: See "Header" section on page 4.
 3. Tolerance for the PCB hole pitch shall be ± 0.05 , and shall not accumulate more than ± 0.05 .
 4. Hole dimensions differ depending on the type of PCB and PCB drilling method.
 The above dimensions are reference values. Please contact JST for details.

PC board layout and Assembly layout/ SMT type

Top entry type

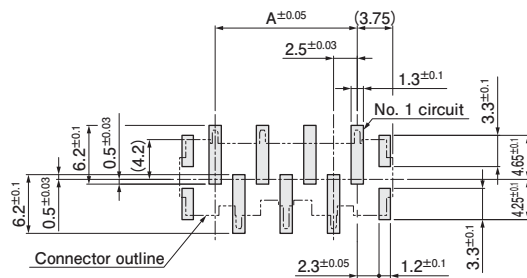

Housing: Standard type

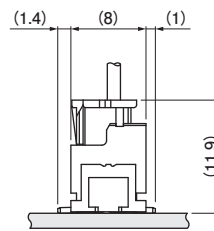

- Note: 1. The PC board layout figure shown is viewed from the connector mounting surface.
 2. Dimension A: See "Header/ SMT type" section on page 6.
 3. Tolerance for the PCB pattern pitch shall be ± 0.03 , and shall not accumulate more than ± 0.05 .
 4. The above dimensions are reference values. Please contact JST for details.

Contact

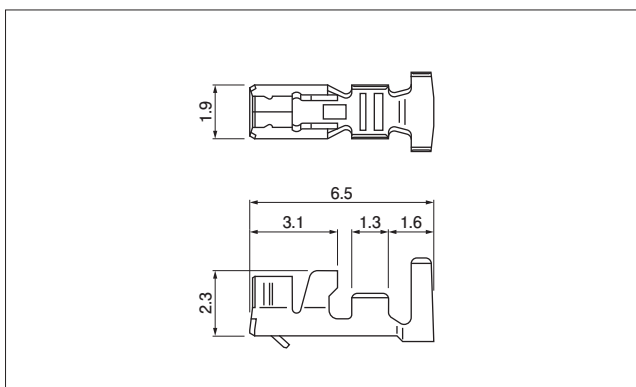

Model No.	Applicable wire range		Q'ty/ reel
	Conductor size AWG (mm ²)	Insulation O.D. (mm)	
SXA-001T-P0.6	#28 to #22 (0.08 to 0.33)	0.8 to 1.9	8,000
SXA-01T-P0.6	#24 to #20 (0.22 to 0.5)	1.5 to 1.9	8,000
SXA-001T-P0.6L	#26 to #22 (0.13 to 0.33)	1.3 to 1.7	8,000

Material and Surface finish, etc.

Phosphor bronze, tin-plated

- Note: 1. SXA-001T-P0.6L is a low-insertion force type contact for easier insertion/withdrawal operation. Please take the application and environment into consideration as the low-insertion force type contact is less resistant to vibration. Please note that the crimp height is different from the standard XA contact.
 2. Contact JST for gold-plated products.

Crimping machine

Contact	Crimping machine	Applicator	Crimp applicator with dies
SXA-001T-P0.6	AP-K2N	MKS-L	APLMK SXA/M001-06
SXA-01T-P0.6			APLMK SXA/M01-06
SXA-001T-P0.6L			APLMK SXA001-06L

Note: Contact JST for fully automatic crimping applicator.

Housing

Standard type

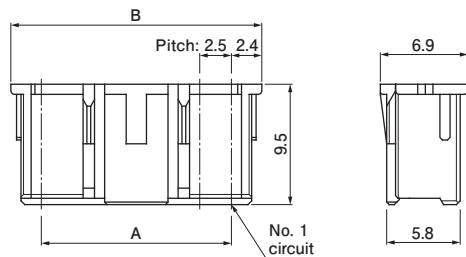

Retainer mountable type

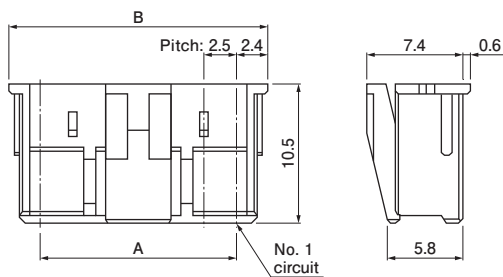

No. of circuits	Model No.		Dimensions (mm)		Q'ty/bag	
	Standard type	Retainer mountable type	A	B	Standard type	Retainer mountable type
2	XAP-02V-1	XARP-02V	2.5	7.3	1,000	1,000
3	XAP-03V-1	XARP-03V	5.0	9.8	1,000	1,000
4	XAP-04V-1	XARP-04V	7.5	12.3	1,000	1,000
5	XAP-05V-1	XARP-05V	10.0	14.8	1,000	1,000
6	XAP-06V-1	XARP-06V	12.5	17.3	1,000	1,000
7	XAP-07V-1	XARP-07V	15.0	19.8	1,000	1,000
8	XAP-08V-1	XARP-08V	17.5	22.3	1,000	1,000
9	XAP-09V-1	XARP-09V	20.0	24.8	1,000	1,000
10	XAP-10V-1	XARP-10V	22.5	27.3	1,000	1,000
11	XAP-11V-1	XARP-11V	25.0	29.8	1,000	1,000
12	XAP-12V-1	XARP-12V	27.5	32.3	1,000	1,000
13	XAP-13V-1	XARP-13V	30.0	34.8	1,000	1,000
14	XAP-14V-1	XARP-14V	32.5	37.3	500	1,000
15	XAP-15V-1	XARP-15V	35.0	39.8	500	1,000
18	—	XARP-18V	42.5	47.3	—	500
20	XAP-20V-1	—	47.5	52.3	500	—

Material and Surface finish, etc.

PA 66, natural (white)

Note: For flame retardant grade of resin material used, please refer to the "List of Registered Overseas Standards" on our website (listed in the "Technical Documents" column on the Product Information page).

Retainer

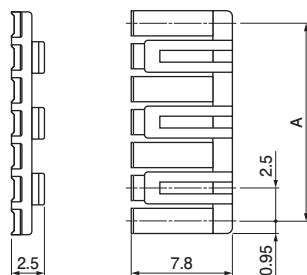

No. of circuits	Model No.	A	Q'ty/bag
2	XMS-02V	2.5	1,000
3	XMS-03V	5.0	1,000
4	XMS-04V	7.5	1,000
5	XMS-05V	10.0	1,000
6	XMS-06V	12.5	1,000
7	XMS-07V	15.0	1,000
8	XMS-08V	17.5	1,000
9	XMS-09V	20.0	1,000
10	XMS-10V	22.5	1,000
11	XMS-11V	25.0	1,000
12	XMS-12V	27.5	1,000
13	XMS-13V	30.0	1,000
14	XMS-14V	32.5	1,000
15	XMS-15V	35.0	1,000

Material and Surface finish, etc.

PA 66 (Glass-filled), natural (ivory)

Note: For flame retardant grade of resin material used, please refer to the "List of Registered Overseas Standards" on our website (listed in the "Technical Documents" column on the Product Information page).

Header/ Through-hole type

Top entry type

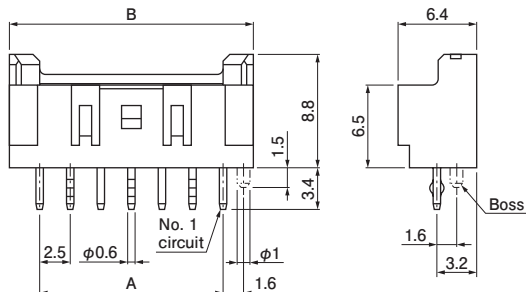

Side entry type • With hook

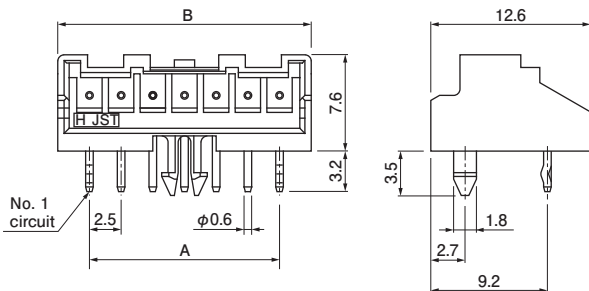

Top entry type

No. of circuits	Model No.		Dimensions (mm)		Q'ty/box
	Without boss	With boss	A	B	
2	B02B-XASK-1	B02B-XASK-1-A	2.5	7.5	1,000
3	B03B-XASK-1	B03B-XASK-1-A	5.0	10.0	400
4	B04B-XASK-1	B04B-XASK-1-A	7.5	12.5	400
5	B05B-XASK-1	B05B-XASK-1-A	10.0	15.0	400
6	B06B-XASK-1	B06B-XASK-1-A	12.5	17.5	400
7	B07B-XASK-1	B07B-XASK-1-A	15.0	20.0	250
8	B08B-XASK-1	B08B-XASK-1-A	17.5	22.5	250
9	B09B-XASK-1	B09B-XASK-1-A	20.0	25.0	250
10	B10B-XASK-1	B10B-XASK-1-A	22.5	27.5	250
11	B11B-XASK-1	B11B-XASK-1-A	25.0	30.0	200
12	B12B-XASK-1	B12B-XASK-1-A	27.5	32.5	200
13	B13B-XASK-1	B13B-XASK-1-A	30.0	35.0	100
14	B14B-XASK-1	B14B-XASK-1-A	32.5	37.5	100
15	B15B-XASK-1	B15B-XASK-1-A	35.0	40.0	100
20	B20B-XASK-1	B20B-XASK-1-A	47.5	52.5	100

Material and Surface finish, etc.

Pin: Copper alloy, copper-undercoated, tin-plated
Wafer: PA 66 (Glass-filled), natural (ivory)

- Note: 1. This product displays (LF)(SN) on a label.
2. Contact JST for gold-plated products.
3. For flame retardant grade of resin material used, please refer to the "List of Registered Overseas Standards" on our website (listed in the "Technical Documents" column on the Product Information page).

Side entry type

No. of circuits	Model No.	Dimensions (mm)		Dimension D (mm)	Q'ty/box
		A	B		
2	S02B-XASK-1	2.5	7.5	1.25	250
3	S03B-XASK-1	5.0	10.0	2.50	250
4	S04B-XASK-1	7.5	12.5	3.75	200
5	S05B-XASK-1	10.0	15.0	5.00	200
6	S06B-XASK-1	12.5	17.5	6.25	200
7	S07B-XASK-1	15.0	20.0	7.50	200
8	S08B-XASK-1	17.5	22.5	8.75	100
9	S09B-XASK-1	20.0	25.0	10.00	100
10	S10B-XASK-1	22.5	27.5	11.25	100
11	S11B-XASK-1	25.0	30.0	12.50	100
12	S12B-XASK-1	27.5	32.5	13.75	100
13	S13B-XASK-1	30.0	35.0	15.00	100
14	S14B-XASK-1	32.5	37.5	16.25	100

Material and Surface finish, etc.

Pin: Copper alloy, copper-undercoated, tin-plated
Wafer: PA 66 (Glass-filled), natural (ivory)

- Note: 1. This product displays (LF)(SN) on a label.
2. Contact JST for gold-plated products.
3. Dimension D shows the dimension of PC board layout.
4. For flame retardant grade of resin material used, please refer to the "List of Registered Overseas Standards" on our website (listed in the "Technical Documents" column on the Product Information page).

Header/ Through-hole type/ N type

Top entry type

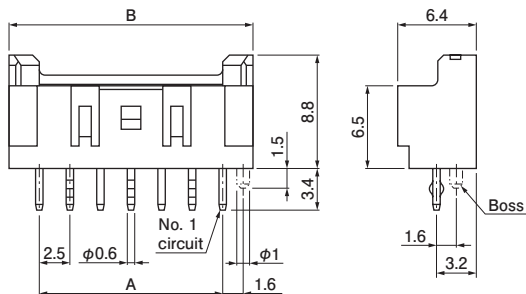

Side entry type

• Without hook

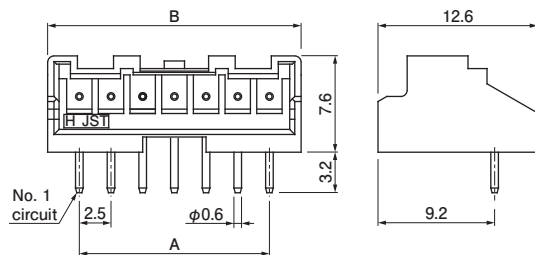

Top entry type

No. of circuits	Model No.		Dimensions (mm)		Q'ty/box
	Without boss	With boss	A	B	
2	B02B-XASK-1N	B02B-XASK-1N-A	2.5	7.5	1,000
3	B03B-XASK-1N	B03B-XASK-1N-A	5.0	10.0	400
4	B04B-XASK-1N	B04B-XASK-1N-A	7.5	12.5	400
5	B05B-XASK-1N	B05B-XASK-1N-A	10.0	15.0	400
6	B06B-XASK-1N	B06B-XASK-1N-A	12.5	17.5	400
7	B07B-XASK-1N	B07B-XASK-1N-A	15.0	20.0	250
8	B08B-XASK-1N	B08B-XASK-1N-A	17.5	22.5	250
9	B09B-XASK-1N	B09B-XASK-1N-A	20.0	25.0	250
10	B10B-XASK-1N	B10B-XASK-1N-A	22.5	27.5	250
11	B11B-XASK-1N	B11B-XASK-1N-A	25.0	30.0	200
12	B12B-XASK-1N	B12B-XASK-1N-A	27.5	32.5	200
13	B13B-XASK-1N	B13B-XASK-1N-A	30.0	35.0	100
14	B14B-XASK-1N	B14B-XASK-1N-A	32.5	37.5	100
15	B15B-XASK-1N	B15B-XASK-1N-A	35.0	40.0	100
18	B18B-XASK-1N	—	42.5	47.5	100

Material and Surface finish, etc.

Pin: Copper alloy, copper-undercoated, tin-plated
Wafer: PA 66 (Glass-filled), natural (white)

Note: 1. This product displays (LF)(SN) on a label.

2. For flame retardant grade of resin material used, please refer to the "List of Registered Overseas Standards" on our website (listed in the "Technical Documents" column on the Product Information page).

Side entry type

No. of circuits	Model No.		Dimensions (mm)		Q'ty/box
	Without hook		A	B	
2	S02B-XASS-1N-BN		2.5	7.5	250
3	S03B-XASS-1N-BN		5.0	10.0	250
4	S04B-XASS-1N-BN		7.5	12.5	200
5	S05B-XASS-1N-BN		10.0	15.0	200
6	S06B-XASS-1N-BN		12.5	17.5	200
7	S07B-XASS-1N-BN		15.0	20.0	200
8	S08B-XASS-1N-BN		17.5	22.5	100
9	S09B-XASS-1N-BN		20.0	25.0	100
10	S10B-XASS-1N-BN		22.5	27.5	100
11	S11B-XASS-1N-BN		25.0	30.0	100
12	S12B-XASS-1N-BN		27.5	32.5	100
13	S13B-XASS-1N-BN		30.0	35.0	100
14	S14B-XASS-1N-BN		32.5	37.5	100

Material and Surface finish, etc.

Pin: Copper alloy, copper-undercoated, tin-plated
Wafer: PA 66 (Glass-filled), natural (white)

Note: 1. This product displays (LF) (SN) on a label.

2. Please note that due to routing, pulling and twisting of the electrical wires, there is risk that the base pin may separate from the PCB. Excessive stress may also affect the solder fillet section on the PCB, thereby weakening header pin retention. We therefore recommend using the side entry header with hooks as a prevention measure. When using the header without hooks, please handle the wire with care.

3. For flame retardant grade of resin material used, please refer to the "List of Registered Overseas Standards" on our website (listed in the "Technical Documents" column on the Product Information page).

Header/ SMT type

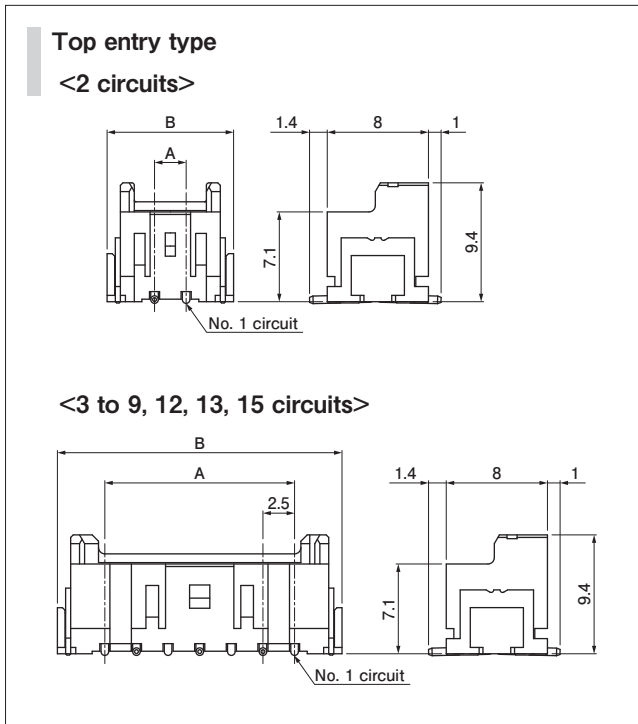

Top entry type

No. of circuits	Model No.	Dimensions (mm)		Q'ty/reel
		A	B	
2	BM02B-XASS-TF	2.5	10.0	500
3	BM03B-XASS-TF	5.0	12.5	500
4	BM04B-XASS-TF	7.5	15.0	500
5	BM05B-XASS-TF	10.0	17.5	500
6	BM06B-XASS-TF	12.5	20.0	500
7	BM07B-XASS-TF	15.0	22.5	500
8	BM08B-XASS-TF	17.5	25.0	500
9	BM09B-XASS-TF	20.0	27.5	500
12	BM12B-XASS-TF	27.5	35.0	500
13	BM13B-XASS-TF	30.0	37.5	500
15	BM15B-XASS-TF	35.0	42.5	500

Material and Surface finish, etc.

Pin: Copper alloy, copper-undercoated, tin-plated
 Wafer: Polyamide, natural
 Reinforcing tab: Brass, copper-undercoated, tin-plated

- Note: 1. This product displays (LF)(SN) on a label.
 2. For flame retardant grade of resin material used, please refer to the "List of Registered Overseas Standards" on our website (listed in the "Technical Documents" column on the Product Information page).

Header/ Radial tapping

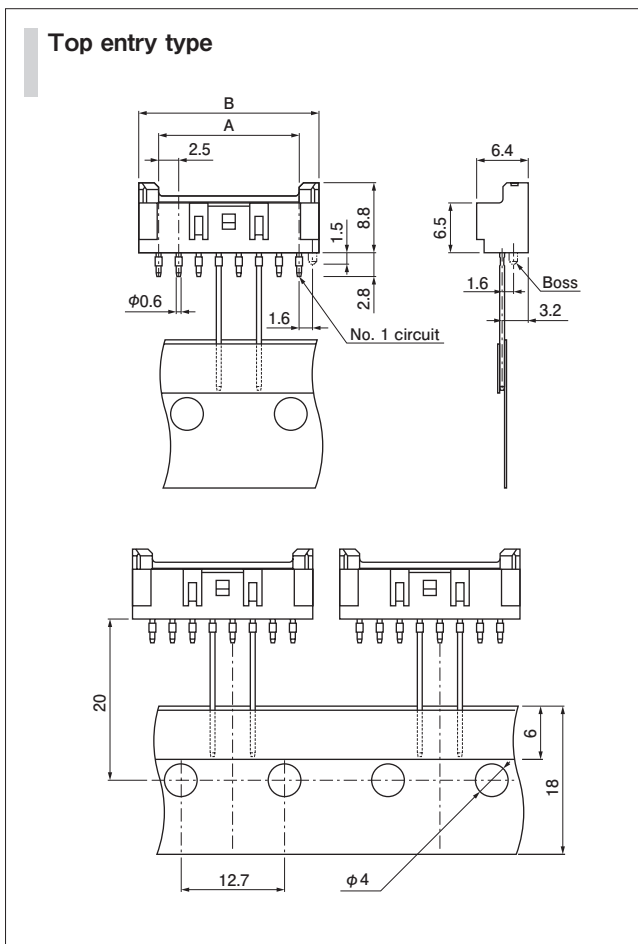

Top entry type

No. of circuits	Model No.		Dimensions (mm)		Q'ty/box
	Without boss	With boss	A	B	
2	B02B-XASS-1-T	—	2.5	7.5	1,000
3	B03B-XASS-1-T	B03B-XASS-1-A-T	5.0	10.0	1,000
4	B04B-XASS-1-T	B04B-XASS-1-A-T	7.5	12.5	500
5	B05B-XASS-1-T	B05B-XASS-1-A-T	10.0	15.0	500
6	B06B-XASS-1-T	B06B-XASS-1-A-T	12.5	17.5	500
7	B07B-XASS-1-T	B07B-XASS-1-A-T	15.0	20.0	500
8	B08B-XASS-1-T	B08B-XASS-1-A-T	17.5	22.5	500

Material and Surface finish, etc.

Pin: Copper alloy, copper-undercoated, tin-plated
 Wafer: PA 66 (Glass-filled), natural (ivory)

- Note: 1. This product displays (LF)(SN) on a label.
 2. This product conforms to IEC 60286-2 (JIC C 0806-2) "Tape packaging of components with unidirectional leads on continuous tapes".
 3. For flame retardant grade of resin material used, please refer to the "List of Registered Overseas Standards" on our website (listed in the "Technical Documents" column on the Product Information page).

Header/ Radial taping

Packaging specifications

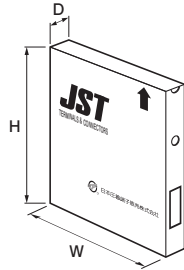

Distance between the end of the tape and the first connector's center line (either end)

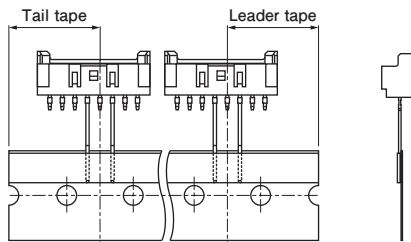

Packaging specifications

Packaging style	Flat pack (zigzag folded)	
Distance between folds	24 index holes per fold (304.8 mm)	
Box size	316 (W) × 45 (D) × 330 (H) mm	
Distance between the end of the tape and the first connector's center line (either end)	19.05 mm	
Quantity per package	2, 3 circuits	1,000 pcs./box
	4 to 8 circuits	500 pcs./box

Note: Products of different packaging specifications are also available. Contact JST for details.

Model number allocation

Contact

S XA - 001 T - P 0.6

Supply form: S...Strip form
B...Loose piece

Series name

Applicable wire range:
Normal type: 001...AWG #28 to AWG #22
01...AWG #24 to AWG #20
Low insertion force type:
001...AWG #26 to AWG #22

Surface finish: Tin-plated

Material: Phosphor bronze

Applicable pin size

Type: Blank...Standard type, L...Low insertion force type

Housing/ Standard type

XAP - 02 V - 1 -

Series name

Type: Plug

No. of circuits

Sub model number

Sub model number

Color: Blank...Natural (White), K...Black, R...Red, E...Blue, Y...Yellow, L...Lemon yellow, M...Green, O...Orange, N...Brown, H...Gray, P...Purple, LE...Light blue, PK...Pink, FY...Fluorescent yellow, Z...Ivory

Housing/ Retainer mountable type

XARP - 02 V -

Series name

Type: Plug (Retainer mountable type)

No. of circuits

Sub model number

Color: Blank...Natural (White), K...Black, R...Red, E...Blue, M...Green, Y...Yellow

Retainer

XM S - 02 V

Series name

Type: Retainer

No. of circuits

Sub model number

Model number allocation

Header/ Through-hole type/ Top entry type

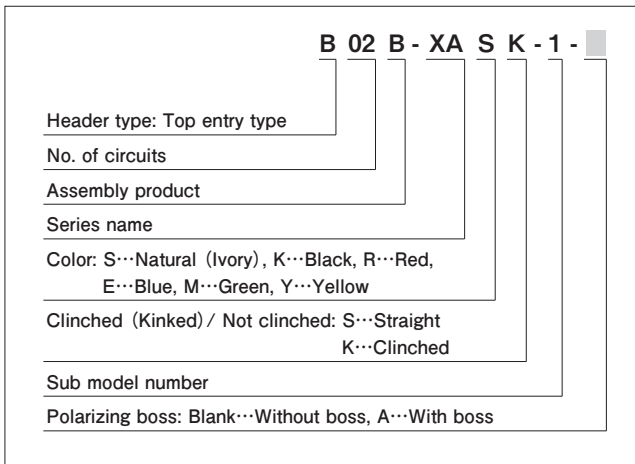

Header/ Through-hole type/ Side entry type

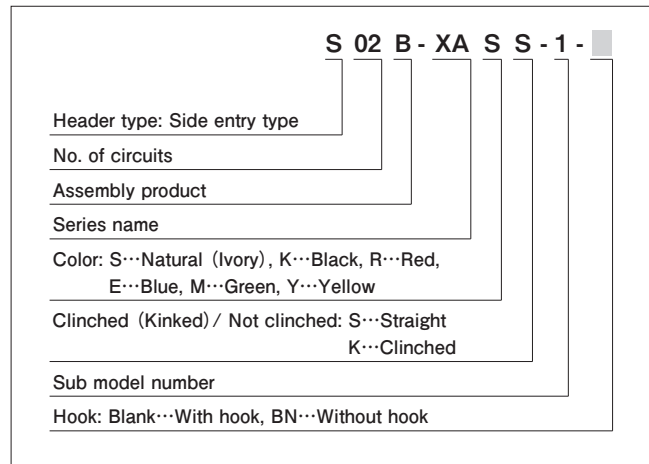

Header/ Through-hole type/ N type/ Top entry type

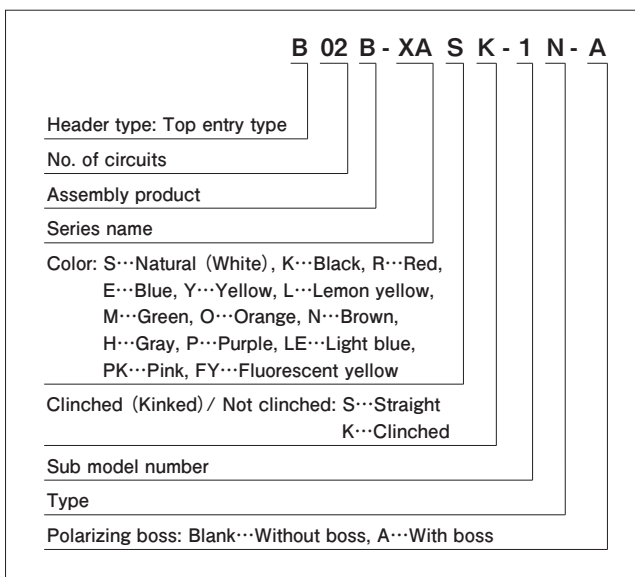

Header/ Through-hole type/ N type/ Side entry type

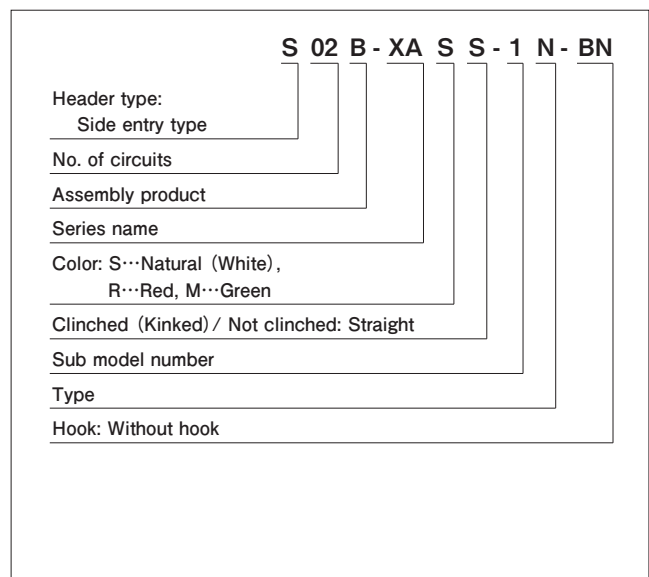

Header/ SMT type

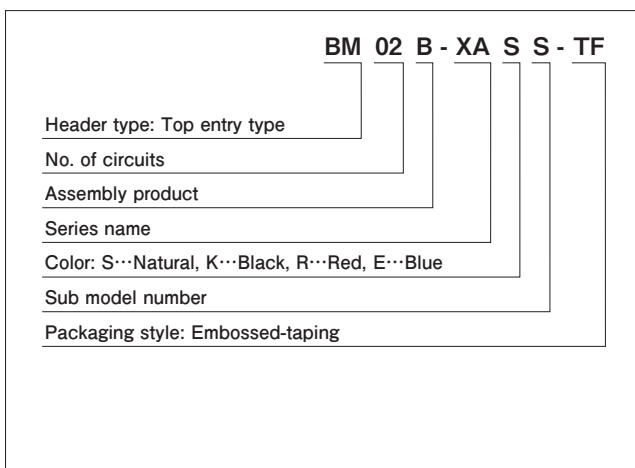

Header/ Radial taping

